

<b>Product</b>	<b>Page No.</b>
<b>Panel Information</b>	
T10-A Panel Profile.....	PV-2
T10-A Panel Overview.....	PV-2
T10-C Panel Profile .....	PV-3
T10-C Panel Overview .....	PV-3
<b>Flashing Profiles</b>	
Cleat .....	PV-4
Custom Soffit Cleat.....	PV-4
Coping .....	PV-4
Outside Corner .....	PV-4
Inside Corner.....	PV-4
Custom Sill/Head.....	PV-4
Custom Sill to Soffit.....	PV-4
Custom Jamb .....	PV-4
Custom Head Channel.....	PV-4
Head/Jamb Cover.....	PV-5
Custom Base.....	PV-5
<b>Accessory Profiles</b>	
Universal Closure .....	PV-5
Touch-Up Paint.....	PV-5
Tape Sealant.....	PV-5
<b>Testing Information</b>	
Section Properties and General Information .....	PV-6-8
<b>Design/Installation Considerations</b>	
Fastening Patterns .....	PV-9
<b>Detail Conditions</b>	
Coping Detail (Vertical).....	PV-10
Coping Detail (Horizontal) .....	PV-10
Outside Corner Detail (Vertical).....	PV-11
Outside Corner Detail (Horizontal) (+option) .....	PV-11
Inside Corner Detail (Vertical).....	PV-12
Inside Corner Detail (Horizontal) (+option).....	PV-12
Sill/Head Detail (Vertical).....	PV-13
Sill/Head Detail (Horizontal) .....	PV-13
Sill to Soffit Detail (Vertical) (+option).....	PV-14
Sill to Soffit Detail (Horizontal) (+option) .....	PV-14
Jamb Detail (Vertical) .....	PV-15
Jamb Detail (Horizontal).....	PV-15
Head Channel Detail (Vertical).....	PV-16
Head Channel Detail (Horizontal).....	PV-16
Base Detail (Vertical).....	PV-17
Base Detail (Horizontal).....	PV-17
<b>Notes</b>	
Notes .....	PV-18

# VERTI-LINE SERIES T10-A PANEL OVERVIEW

## T10A PANEL PROFILE

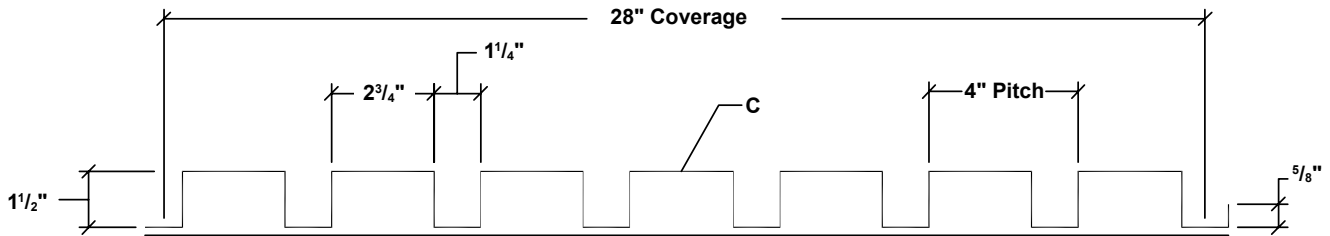

### SUBSTRATE

T10A panel is designed to be utilized over open structural framing, but can easily be used with a solid substrate. The recommended substrate is 5/8" plywood with a 30 pound felt moisture barrier. To avoid panel distortion, use a properly aligned and uniform substructure.

### COVERAGE

Each panel has a coverage of 28".

### LENGTH

Lengths under 5'-0" are available with some cutting restrictions. Please consult your Metal Sales branch for maximum panel lengths and recommendations (see PGI-2 and PGI-3 for locations).

### AVAILABILITY

Panels are available in 24 through 18 gauge. Minimum quantities may apply. Custom capabilities include:

- Perforated panels for wind screens and liner panels.
- Depth of panel.

### APPLICATION

Commercial, Industrial, and Architectural panels.

### FASTENING SYSTEM

Direct Fastened (exposed).

### FASTENERS

The fastener selection guide should be consulted for choosing proper fasteners for specific applications. Quantity and type of fastener must meet necessary loading and code requirements (see PGI-12-14).

### MATERIALS

Steel grade 50, per ASTM A-792. Optional material: stainless steel, weathering steel, copper, and aluminum.

### FINISH

- ▶ \*Acrylic Coated Galvalume® (ACG) / ASTM A-792 - AZ55
- ▶ Prepainted Galvalume / ASTM A-792 - AZ50
- ▶ MS Colorfast45®
- ▶ \*\*Fluorocarbon (PVDF)
- ▶ Multi-Pass Kynar
- ▶ Marbilique
- ▶ Plastisol
- ▶ Polyester

\* Differential appearance of Acrylic Coated Galvalume roofing materials is not a cause for rejection.

\*\* Meets both Kynar 500 and Hylar 5000 specifications.

# VERTI-LINE SERIES T10-C PANEL OVERVIEW

## T10C PANEL PROFILE

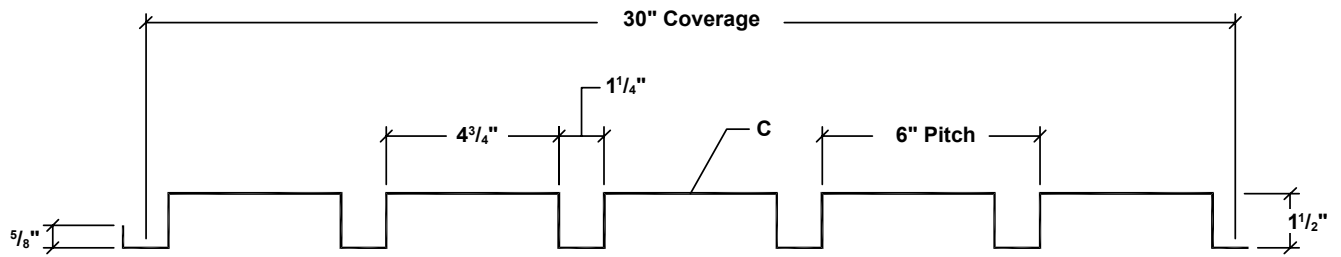

### SUBSTRATE

T10C panel is designed to be utilized over open structural framing, but can easily be used with a solid substrate. The recommended substrate is 5/8" plywood with a 30 pound felt moisture barrier. To avoid panel distortion, use a properly aligned and uniform substructure.

### COVERAGE

Each panel has a coverage of 30".

### LENGTH

Lengths under 5'-0" are available with some cutting restrictions. Please consult your Metal Sales branch for maximum panel lengths and recommendations (see PGI-2 and PGI-3 for locations).

### AVAILABILITY

Panels are available in 24 through 18 gauge. Minimum quantities may apply. Custom capabilities include:

- Perforated panels for wind screens and liner panels.
- Depth of panel.

### APPLICATION

Commercial, Industrial panels.

### FASTENING SYSTEM

Direct Fastened (exposed).

### FASTENERS

The fastener selection guide should be consulted for choosing proper fasteners for specific applications. Quantity and type of fastener must meet necessary loading and code requirements (see PGI-12-14).

### MATERIALS

Steel grade 50, per ASTM A-792. Optional material: stainless steel, weathering steel, copper, and aluminum.

### FINISH

- ▶ Acrylic Coated Galvalume® (ACG) / ASTM A-792 - AZ55
- ▶ Prepainted Galvalume / ASTM A-792 - AZ50
- ▶ MS Colorfast45®
- ▶ \*\*Fluorocarbon (PVDF)
- ▶ Multi-Pass Kynar
- ▶ Marbilique
- ▶ Plastisol
- ▶ Polyester

\* Differential appearance of Acrylic Coated Galvalume roofing materials is not a cause for rejection.

\*\* Meets both Kynar 500 and Hylar 5000 specifications.

**CLEAT**

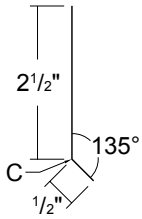

Length 10'-0"

**CUSTOM SOFFIT CLEAT**

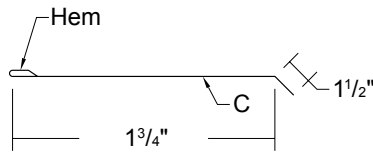

Length 10'-0"

**COPING**

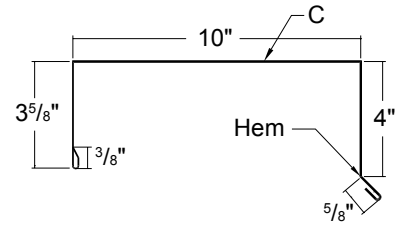

Length 10'-0"

**OUTSIDE CORNER**

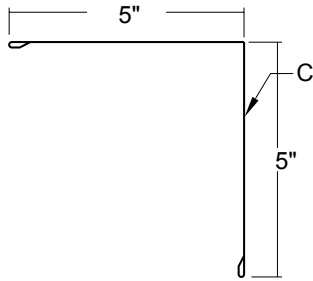

Length 10'-0"

**INSIDE CORNER**

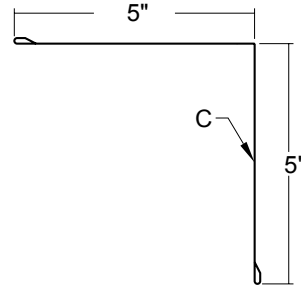

Length 10'-0"

**CUSTOM SILL/HEAD**

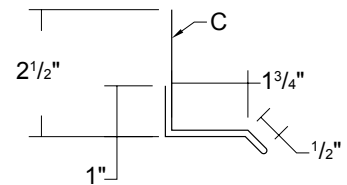

Length 10'-0"

**CUSTOM SILL TO SOFFIT**

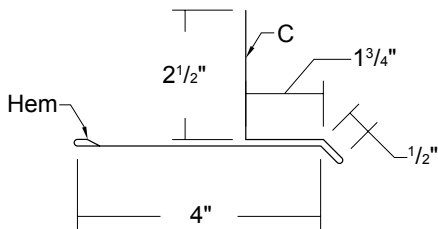

Length 10'-0"

**CUSTOM JAMB**

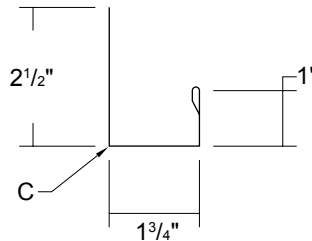

Length 10'-0"

**CUSTOM HEAD CHANNEL**

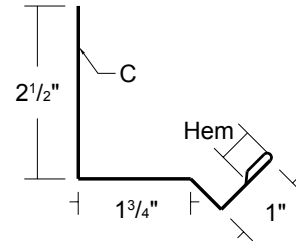

Length 10'-0"

**HEAD/JAMB COVER**

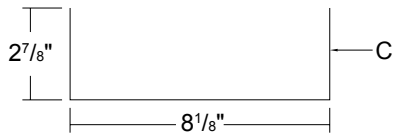

Length 10'-0"

**CUSTOM BASE**

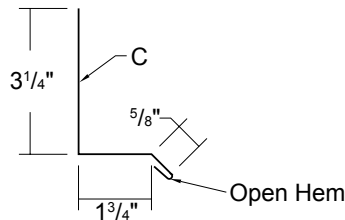

Length 10'-0"

C- Indicates color side of flashing.

**UNIVERSAL CLOSURE**

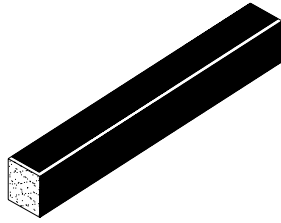

1" x 1 1/2" x 50' Polyethylene Foam  
1" x 1 1/2" x 10' Polyethylene Foam

**TOUCH-UP PAINT**

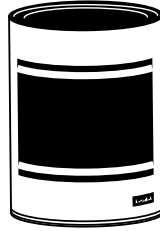

Available in pints  
PVDF / MS Colorfast45

**TAPE SEALANT**



3/8" X 3/32" X 50'  
Single Bead  
Butyl - Gray

**T-10A CLOSURES**



Inside Closure



Outside Closure

Polyethylene Foam

**T-10C CLOSURES**



Inside Closure

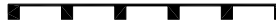

Outside Closure

Polyethylene Foam

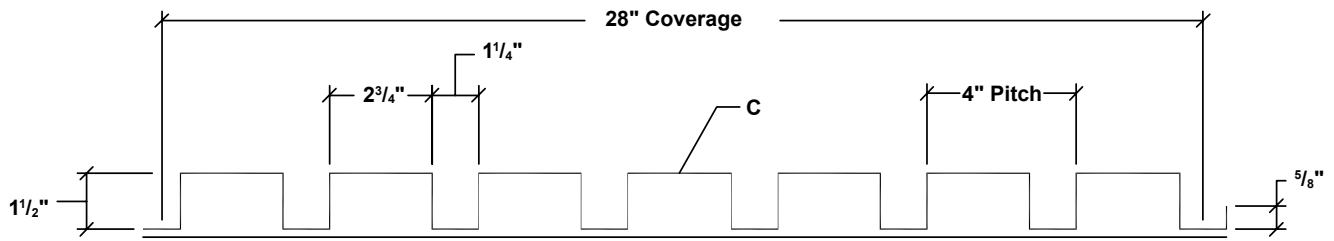

SECTION PROPERTIES								ALLOWABLE UNIFORM LOADS PSF (3 or More Equal Spans)											
Ga.	Width (in.)	Yield KSI	Weight PSF	Top in Compression		Bottom in Compression		Inward Load						Outward Load					
				Ixx In <sup>4</sup> /ft	Sxx In <sup>3</sup> /ft	Ixx In <sup>4</sup> /ft	Sxx In <sup>3</sup> /ft	5'	6'	7'	8'	10'	12'	5'	6'	7'	8'	10'	12'
24	28"	50	1.60	0.1221	0.1569	0.1539	0.1657	153	107	79	54	28	16	145	101	74	54	28	16
22	28"	50	2.10	0.1736	0.2275	0.2130	0.2358	217	152	106	71	36	21	210	146	106	71	36	21
20	28"	33	2.52	0.2314	0.2790	0.2529	0.2835	172	120	89	68	42	25	170	118	87	67	42	25
18	28"	33	3.32	0.3257	0.3699	0.3300	0.3686	224	156	115	88	54	31	225	157	116	89	54	31

- Theoretical section properties have been calculated per AISI 2001. "Specifications for the Design of Cold-formed Steel Structural Members." Ixx and Sxx are effective section properties for deflection and bending.
- Allowable load is calculated in accordance with AISI 2001 specifications considering bending, shear, combined bending and shear and deflection. Allowable load considers both 3 and 4 equal span conditions. Allowable load does not address web crippling or fasteners/support connection. Panel weight is not considered.
- Deflection consideration is limited by a maximum deflection ratio of L/180 of span.
- Allowable loads do not include a 1/3 stress increase in uplift.

**ATTACHMENT DETAIL**

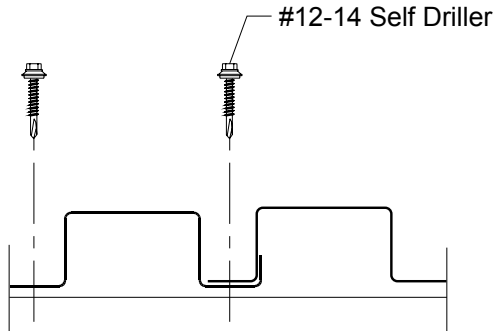

**FASTENING PATTERNS**

**Ends of Panel**

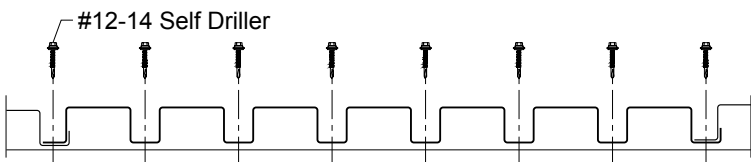

**Field of Panel**

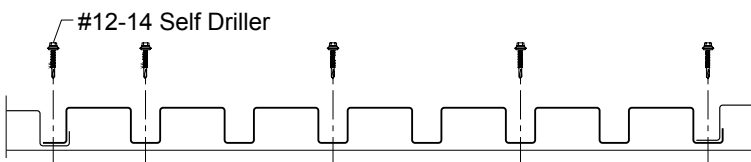

**GENERAL INFORMATION**

► **Substructure**

T10-A Panels are designed to be utilized over open structural framing or a solid substrate.

► **Coverage**

T10-A Panels are available in a 1 1/2" depth with a coverage width of 28".

► **Length**

Minimum factory cut length is 5'-0".  
Maximum available panel length is 32'-0".

► **Fasteners**

The fastener selection guide should be consulted for choosing the proper fastener for specific applications. Quantity and type of fastener must meet necessary loading and code requirements.

*NOTE: All panels are subject to surface distortion due to improperly applied fasteners. Overdriven fasteners will cause stress and induce oil canning across the face of the panel at or near the point of attachment.*

► **Availability**

*Finishes:* Kynar 500 (PVDF) standard; optional: multi-pass Kynar, Marblique, Plastisol, Polyester, and MS Colorfast45<sup>®</sup> (SMP)  
*Gauges:* 24ga, 22ga, 20ga and 18ga

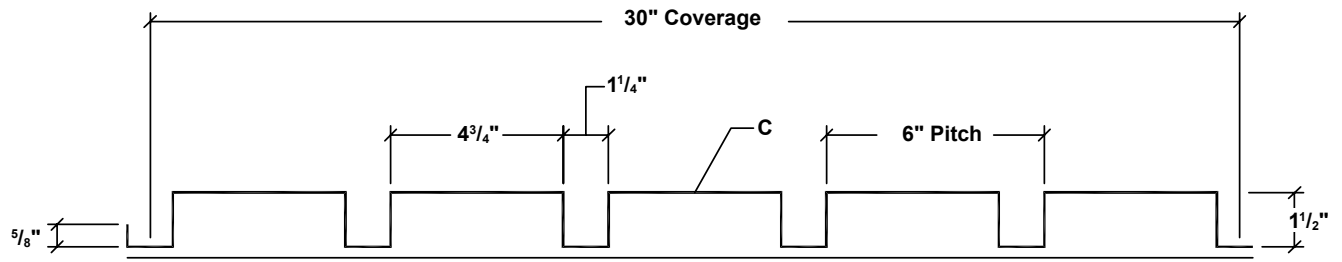

SECTION PROPERTIES								ALLOWABLE UNIFORM LOADS PSF (3 or More Equal Spans)											
Ga.	Width (in.)	Yield KSI	Weight PSF	Top in Compression		Bottom in Compression		Inward Load						Outward Load					
				I <sub>xx</sub> In <sup>4</sup> /ft	S <sub>xx</sub> In <sup>3</sup> /ft	I <sub>xx</sub> In <sup>4</sup> /ft	S <sub>xx</sub> In <sup>3</sup> /ft	5'	6'	7'	8'	10'	12'	5'	6'	7'	8'	10'	12'
24	30"	50	1.36	0.0840	0.1075	0.1252	0.1190	110	77	56	43	23	13	99	69	51	39	23	13
22	30"	50	1.80	0.1204	0.1578	0.1752	0.1696	156	109	80	59	30	18	146	101	75	57	30	18
20	30"	33	2.13	0.1640	0.1949	0.2120	0.2058	125	87	64	49	32	21	118	83	61	47	30	21
18	30"	33	2.80	0.2400	0.2606	0.2760	0.2687	163	114	84	64	41	26	158	110	81	62	40	26

- Theoretical section properties have been calculated per AISI 2001. "Specifications for the Design of Cold-formed Steel Structural Members." I<sub>xx</sub> and S<sub>xx</sub> are effective section properties for deflection and bending.
- Allowable load is calculated in accordance with AISI 2001 specifications considering bending, shear, combined bending and shear and deflection. Allowable load considers both 3 and 4 equal span conditions. Allowable load does not address web crippling or fasteners/support connection. Panel weight is not considered.
- Deflection consideration is limited by a maximum deflection ratio of L/180 of span.
- Allowable loads do not include a 1/3 stress increase in uplift.

**ATTACHMENT DETAIL**

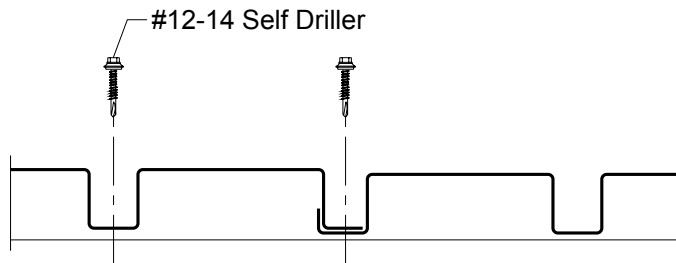

**FASTENING PATTERNS**

**Ends of Panel**

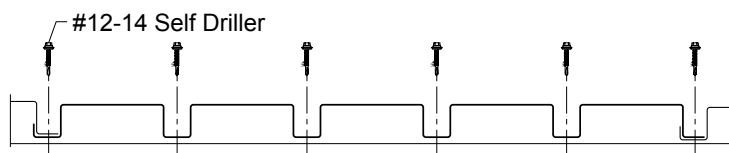

**Field of Panel**

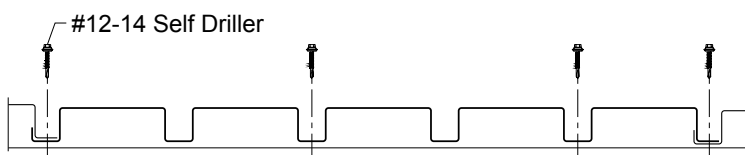

**GENERAL INFORMATION**

► **Substructure**

T10-C Panels are designed to be utilized over open structural framing or a solid substrate.

► **Coverage**

T10-C Panels are available in a 1 1/2" depth with a coverage width of 30".

► **Length**

Minimum factory cut length is 5'-0".  
Maximum available panel length is 32'-0".

► **Fasteners**

The fastener selection guide should be consulted for choosing the proper fastener for specific applications. Quantity and type of fastener must meet necessary loading and code requirements.

*NOTE: All panels are subject to surface distortion due to improperly applied fasteners. Overdriven fasteners will cause stress and induce oil canning across the face of the panel at or near the point of attachment.*

► **Availability**

Finishes: Kynar 500 (PVDF) standard;  
optional: multi-pass Kynar, Marblique, Plastisol, Polyester, and MS Colorfast45® (SMP)  
Gauges: 24ga, 22ga, 20ga and 18ga

**FASTENER INSTALLATION TECHNIQUE**

**Recommended Tool Type** - Use depth locating nose or adjustable clutch on screw gun to prevent overdrilling and strip out. **Do not use impact tools or runners.**

**Seating the washer** - Apply sufficient torque to seat the washer - do not overdrive the fastener.

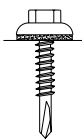
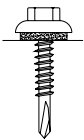
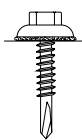
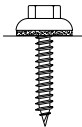
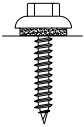
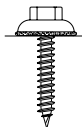
	<b>CORRECT</b> Sealing material slightly visible at edge of metal washer. Assembly is watertight.	<b>TOO LOOSE</b> Sealing material is not visible; not enough compression to seal properly.	<b>TOO TIGHT</b> Metal washer deformed; sealing material pressed beyond washer edge.
<b>SELF DRILLER</b>			
<b>WOODSCREW</b>			

**To prevent wobbling** - Make sure fastener head is completely engaged in the socket. If the head does not go all the way in the socket - tap the magnet deeper into the socket to allow full head engagement. Metal chips will build up from drilling and should be removed from time to time.

**Protect drill point** - Push only hard enough on the screw gun to engage clutch. This prevents excess friction and burn out of the drill point. Correct pressure will allow screw to drill and tap without binding.

**Drilling through sheet and insulation** - Ease up on pressure when drilling through insulation to avoid striking the purlin or girt with the point - apply more pressure after drill point contacts purlin or girt.

**Drilling through purlin overlaps** - Drilling through lapped purlins requires extra care. Excessive voids between purlins sometimes damages drill points and two self-drillers might be necessary to complete the operation. It is sometimes advantageous to predrill.

**CONDITION OF SUBSTRUCTURE**

Whether over solid substrate or open structural framing, panel distortion may occur if not applied over properly aligned and uniform substructure.

The installer should check the roof deck for squareness before installing Verti-Line panels. Several methods can be used to verify squareness of the structure for proper installation of the panels.

**METHOD "A"** - One method for checking the roof for squareness is to measure diagonally across one slope of the roof from similar points at the ridge and eave and obtain the same dimension.

**METHOD "B"** - The 3-4-5 triangle system may also be used. To use this system measure a point from the corner along the edge of the roof at a module of three (3). Measure a point from the same corner along another edge at a module of four (4). Then by measuring diagonally between the two points established, the dimension should be exactly a module of five (5) to have a square corner. Multiple uses of this system may be required to determine building squareness. If the endwall cannot be made square, the roof system cannot be installed as shown in these instructions.

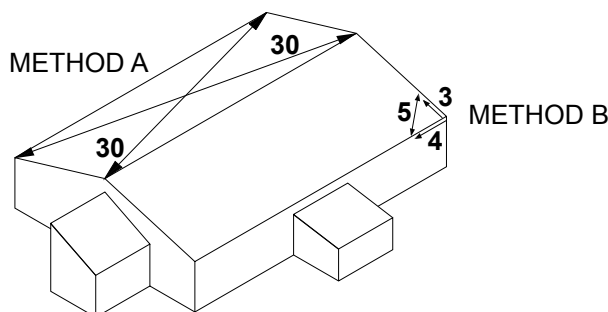

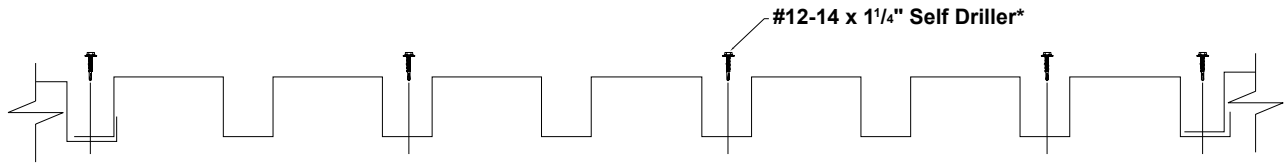
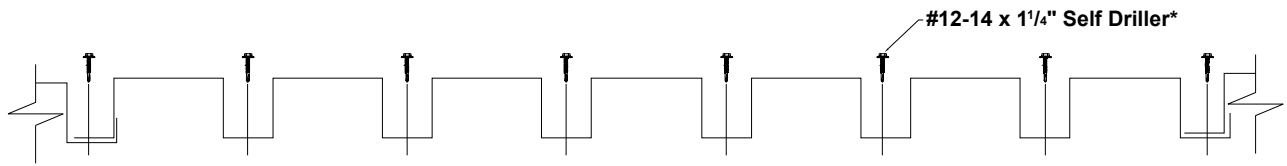

**T10-A FASTENING PATTERNS****T10-A-Panel Fastening Pattern in field****T10-A-Panel Fastening Pattern at Ends**

Note: #12-14 x 1" Self Driller is used for non-insulated applications.

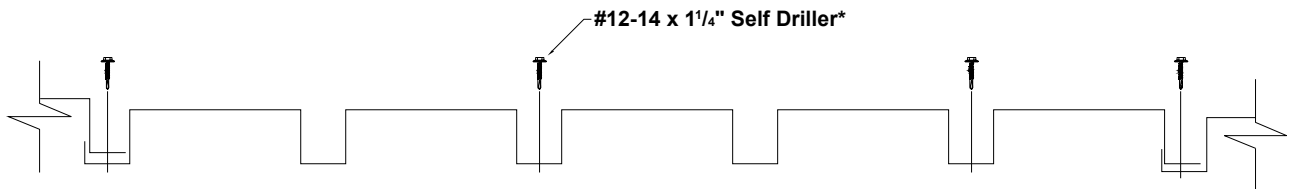
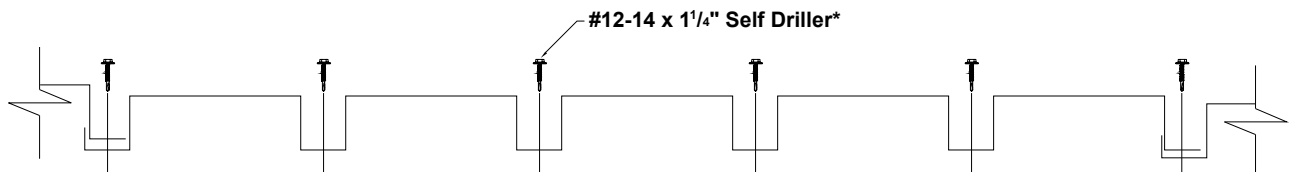
**T10-C FASTENING PATTERNS****T10-C-Panel Fastening Pattern in Field****T10-C-Panel Fastening Pattern at Ends**

Note: #12-14 x 1" Self Driller is used for non-insulated applications.

**VERTI-LINE SERIES COPING DETAIL (VERTICAL)**

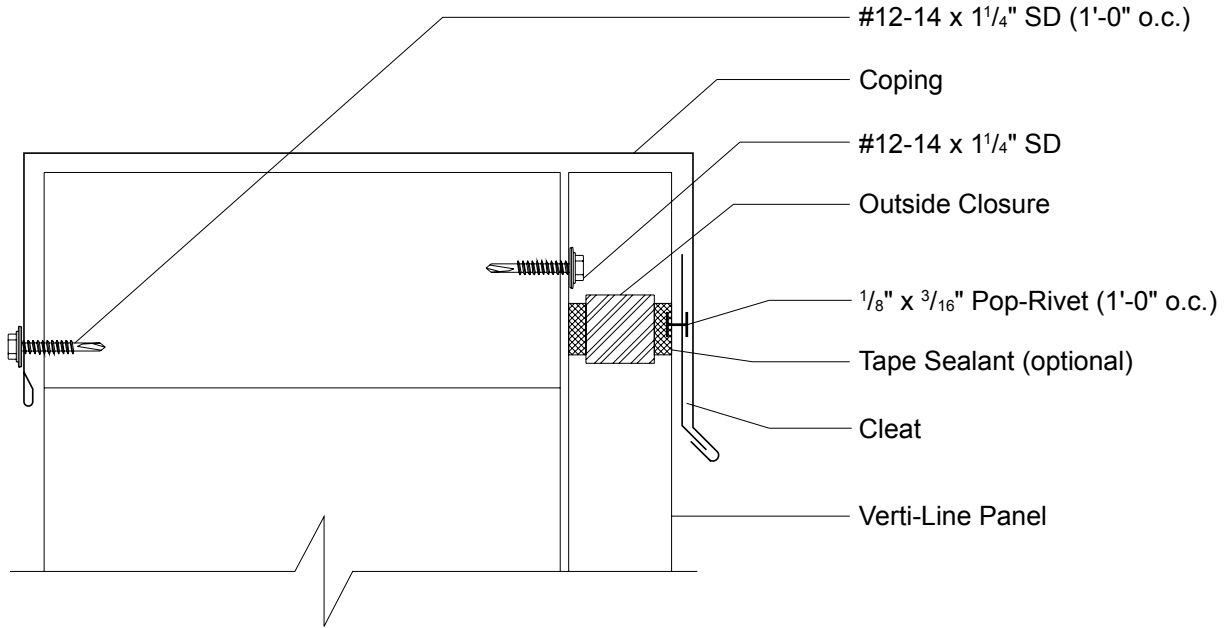

**VERTI-LINE SERIES COPING DETAIL (HORIZONTAL)**

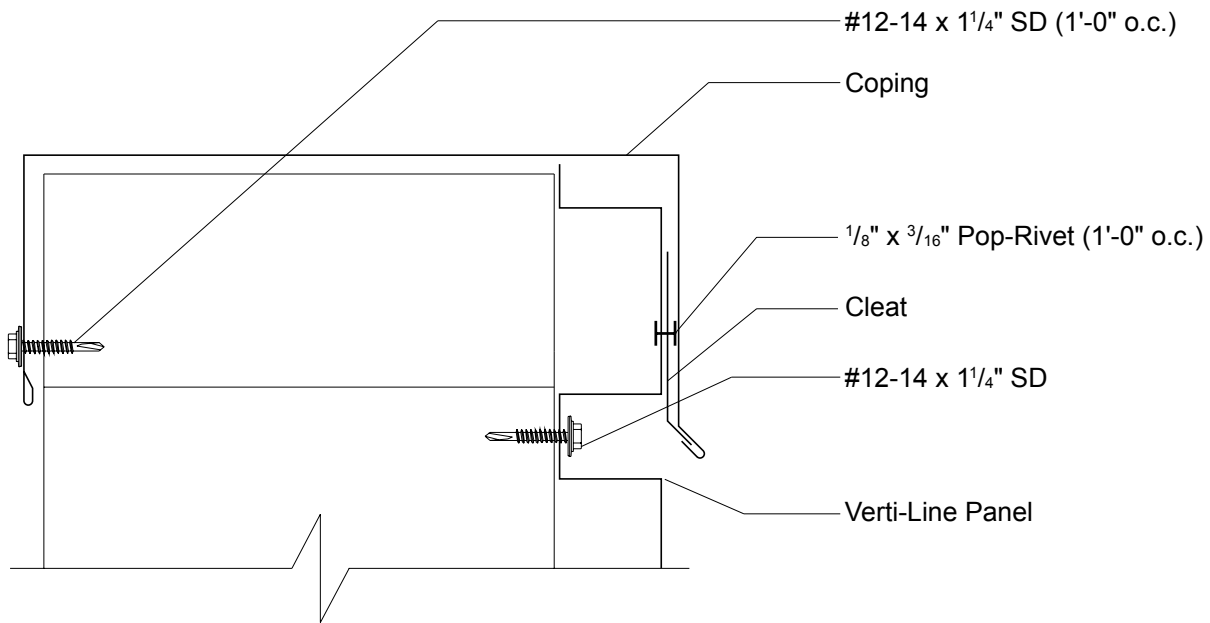

**VERTI-LINE SERIES OUTSIDE CORNER DETAIL (VERTICAL)**

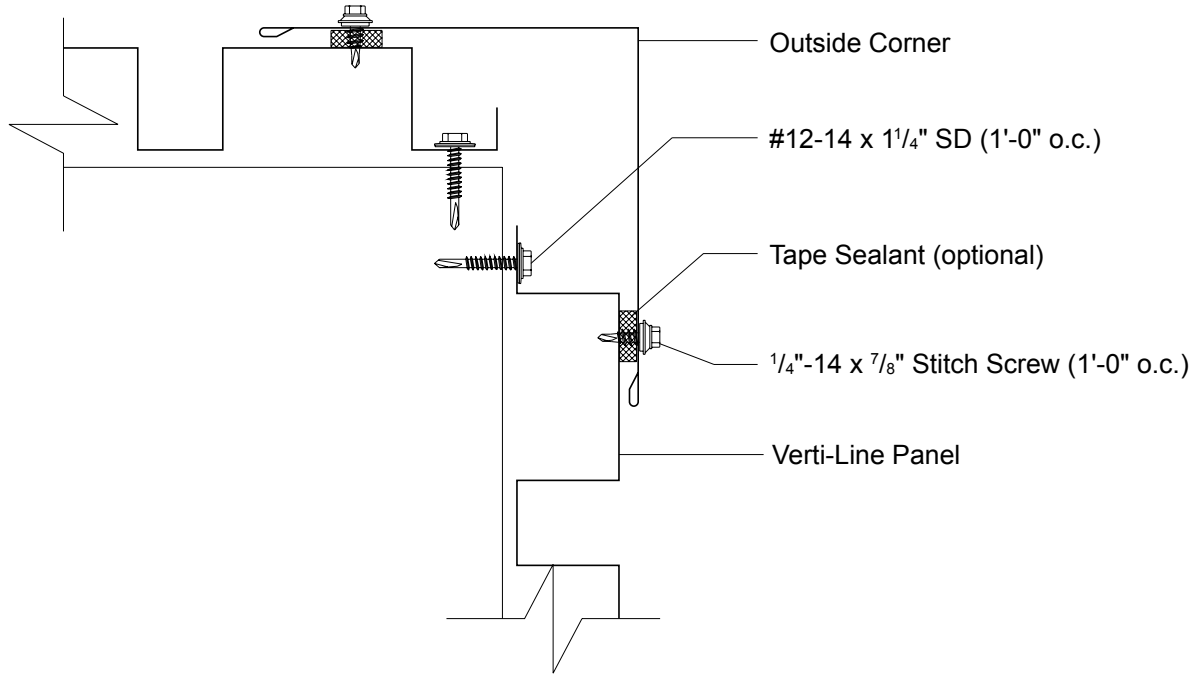

**VERTI-LINE SERIES OUTSIDE CORNER DETAIL (HORIZONTAL) AND OPTION**

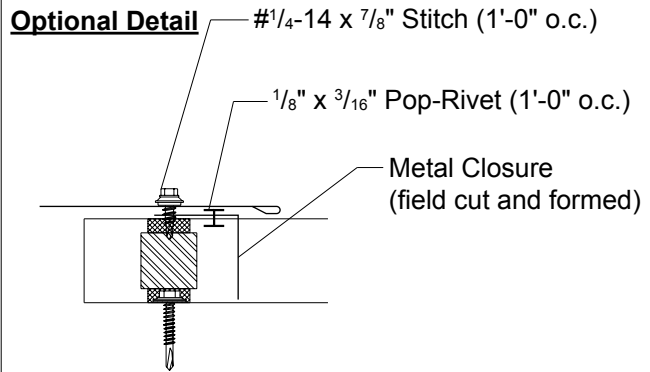
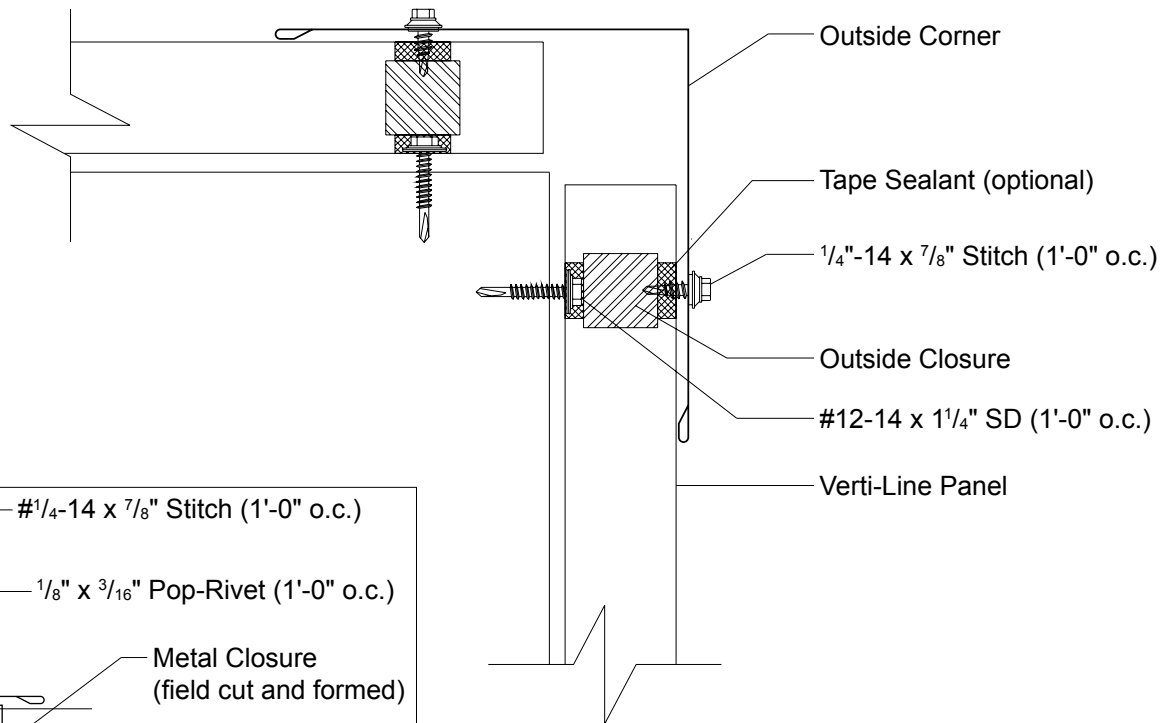

# VERTI-LINE SERIES INSIDE CORNER DETAIL (VERTICAL)

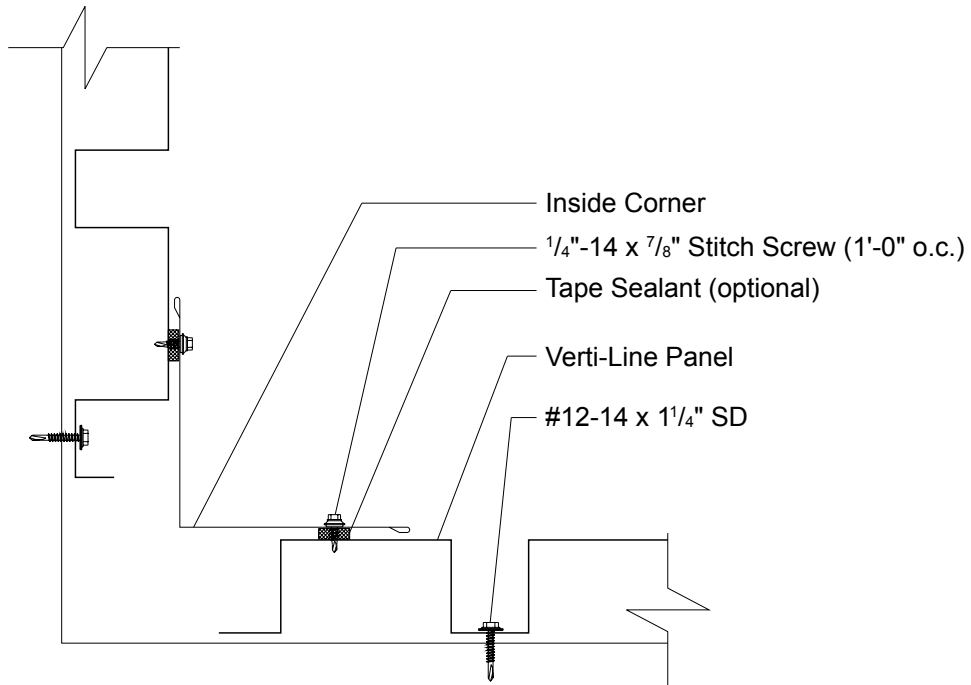

# VERTI-LINE SERIES INSIDE CORNER DETAIL (HORIZONTAL) AND OPTION

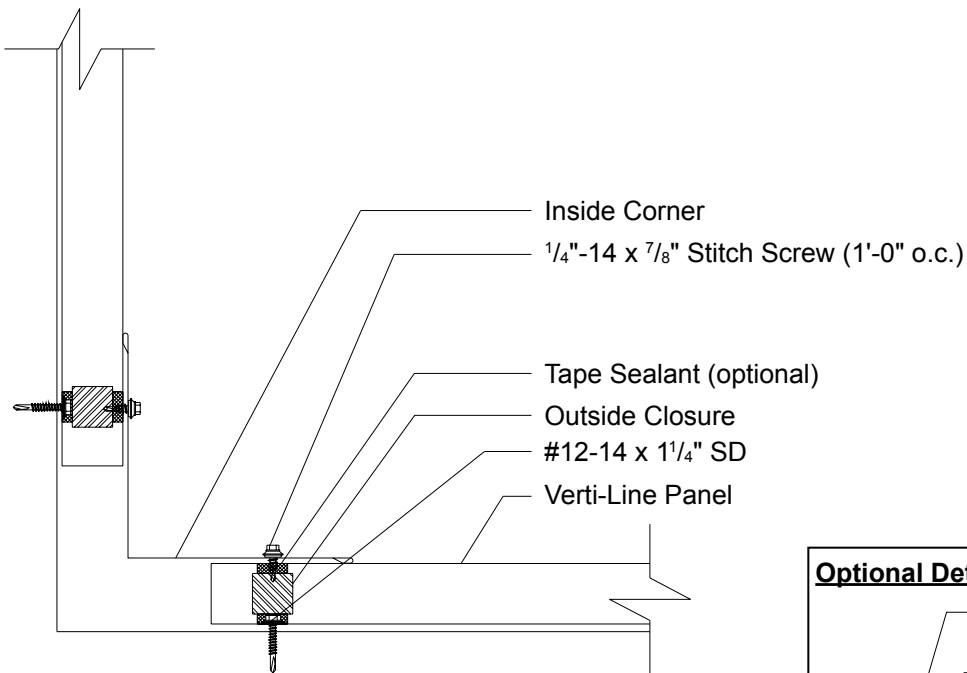

## Optional Detail

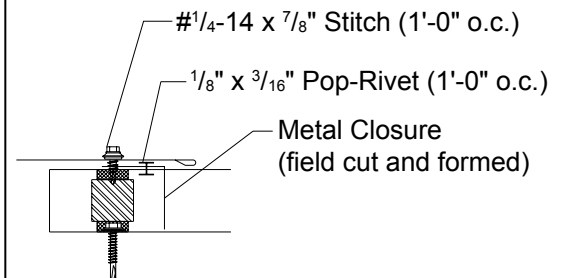

**VERTI-LINE SERIES SILL/HEAD DETAIL (VERTICAL)**

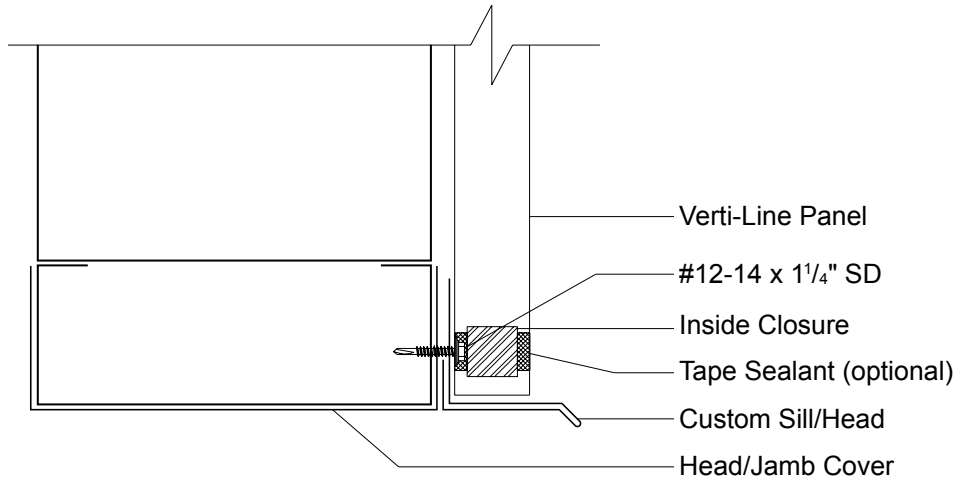

**VERTI-LINE SERIES SILL/HEAD DETAIL (HORIZONTAL)**

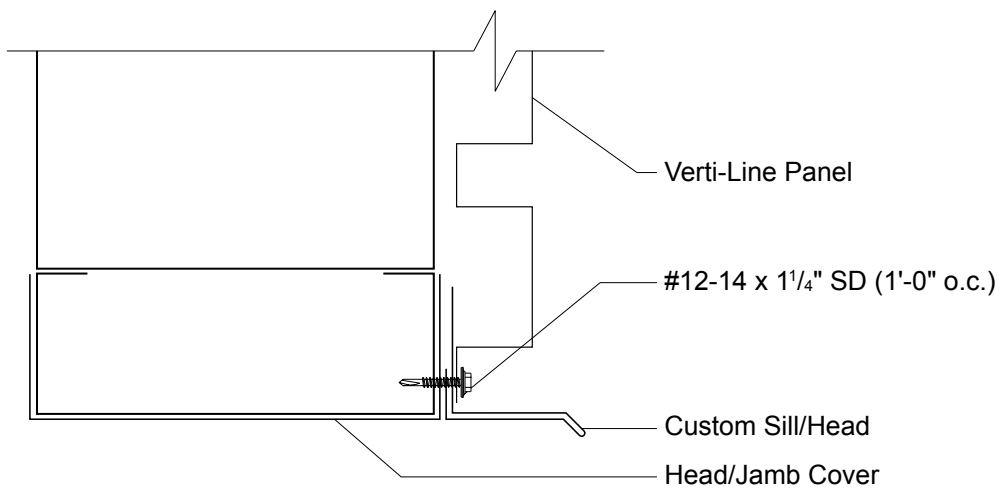

**VERTI-LINE SERIES SILL TO SOFFIT DETAIL (VERTICAL) AND OPTION**

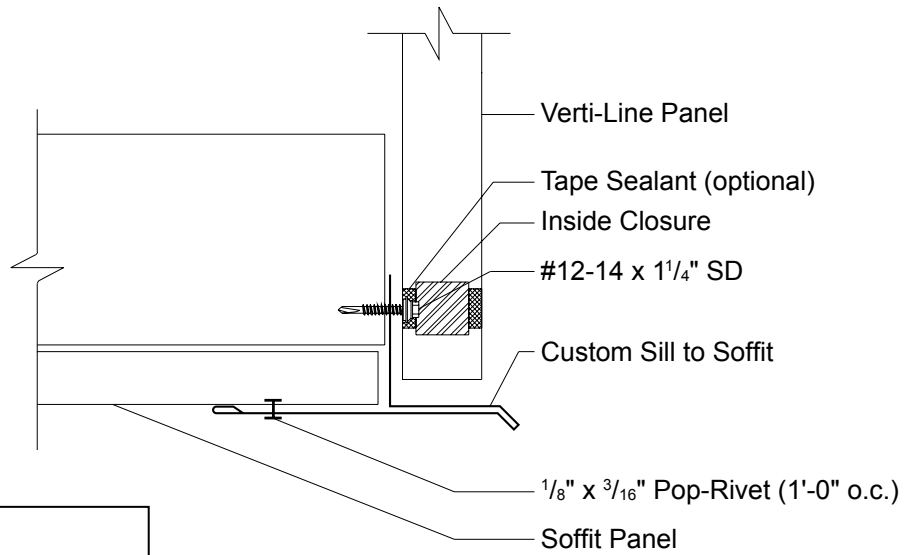

**Optional Detail**

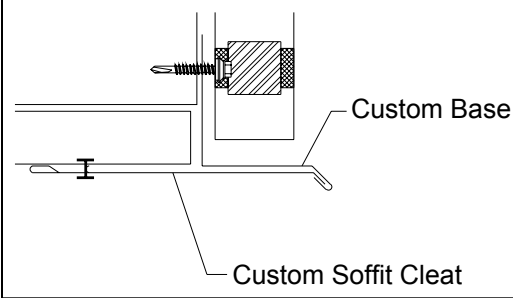

**VERTI-LINE SERIES SILL TO SOFFIT DETAIL (HORIZONTAL) AND OPTION**

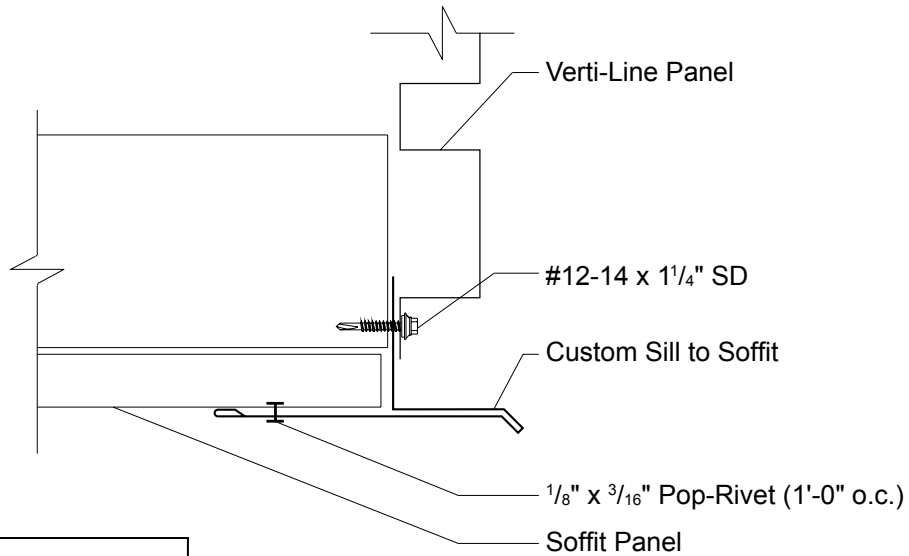

**Optional Detail**

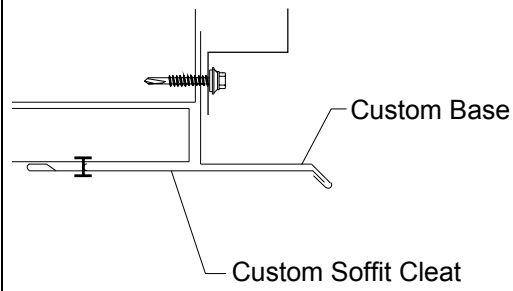

**VERTI-LINE SERIES JAMB DETAIL (VERTICAL)**

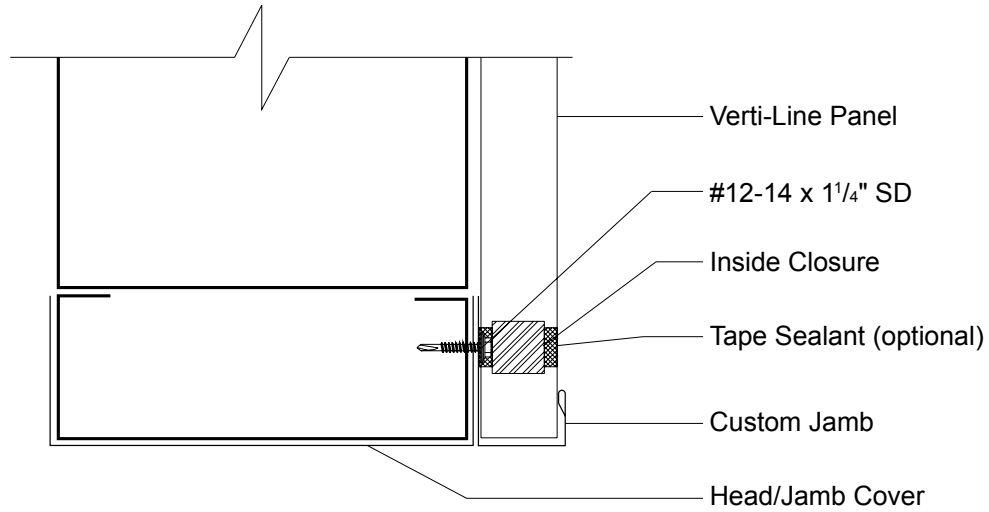

**VERTI-LINE SERIES JAMB DETAIL (HORIZONTAL)**

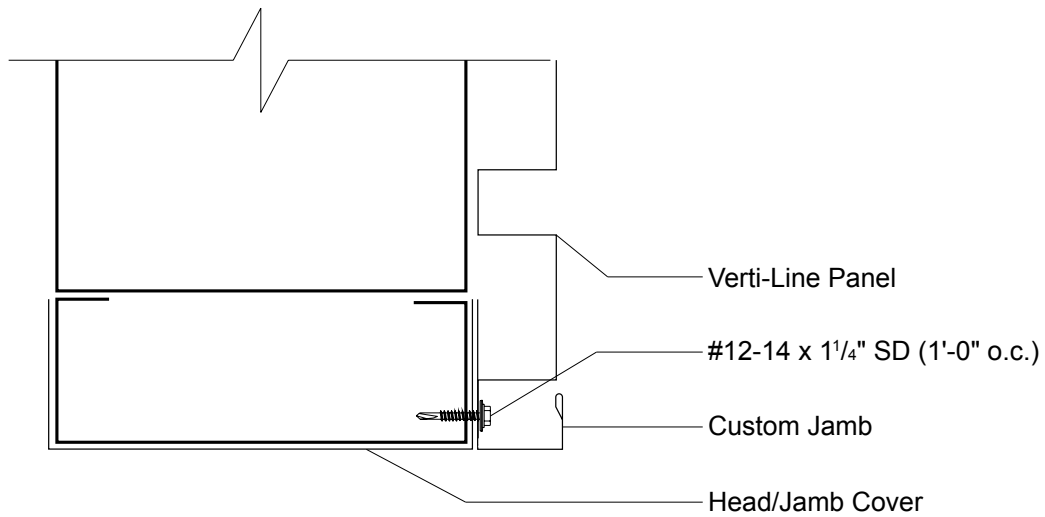

**VERTI-LINE SERIES HEAD CHANNEL DETAIL (VERTICAL)**

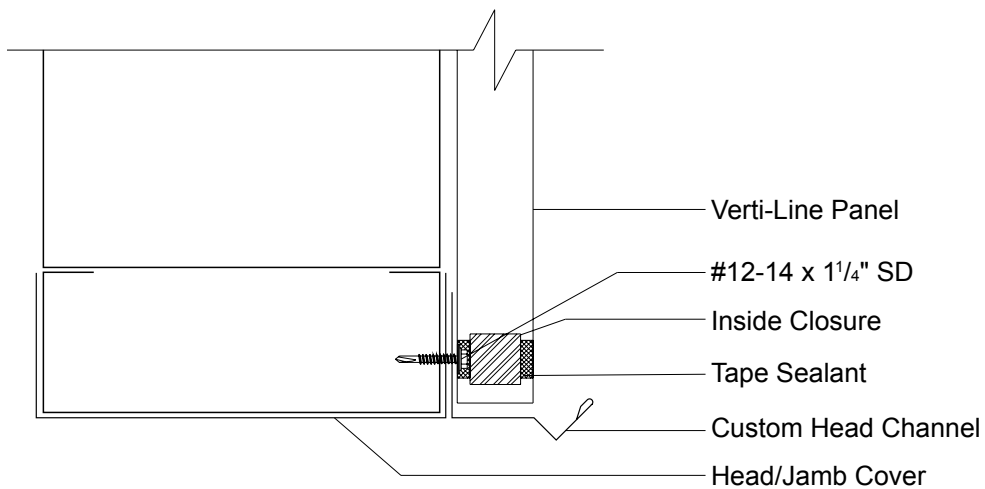

**VERTI-LINE SERIES HEAD CHANNEL DETAIL (HORIZONTAL)**

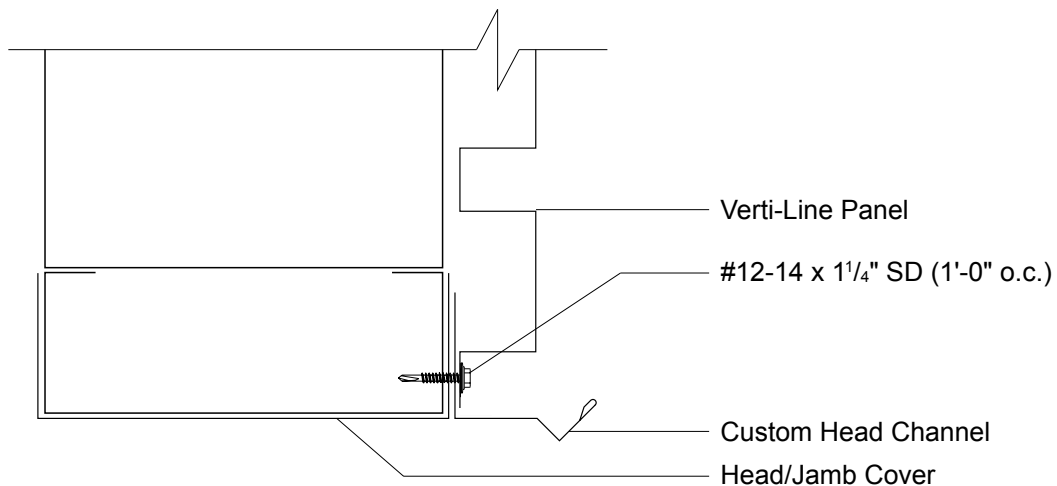



**VERTI-LINE SERIES** BASE DETAIL (VERTICAL)

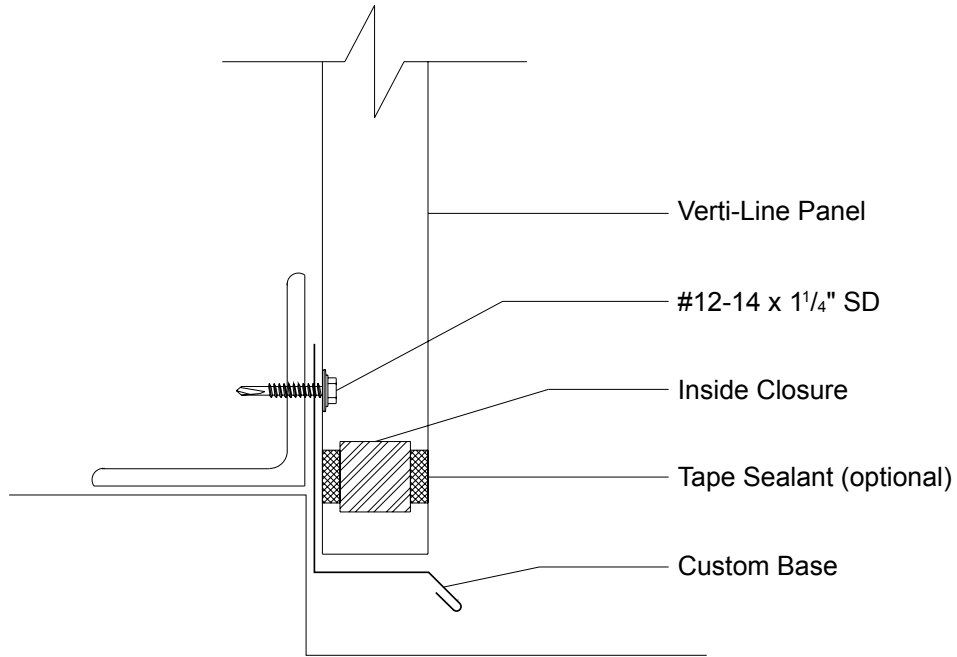

**VERTI-LINE SERIES** BASE DETAIL (HORIZONTAL)

